

**VEVOR**



**DUAL SPEED POOL PUMP**  
**USER MANUAL**

# VEVOR<sup>®</sup>

VVPS215BUS(1.5HP 230V)

VVPS220BUS(2.0HP 230V)

*Instruction Manual*



## NEED HELP? CONTACT US!

Have product questions? Need technical support? Please feel free to contact us:

 [CustomerService@vevor.com](mailto:CustomerService@vevor.com)

**IMPORTANT :** Be sure to review the contents of this manual before attempting to operate the equipment. This manual should be located where it can be easily referenced by all users of the machine.

## MAIN PARTS

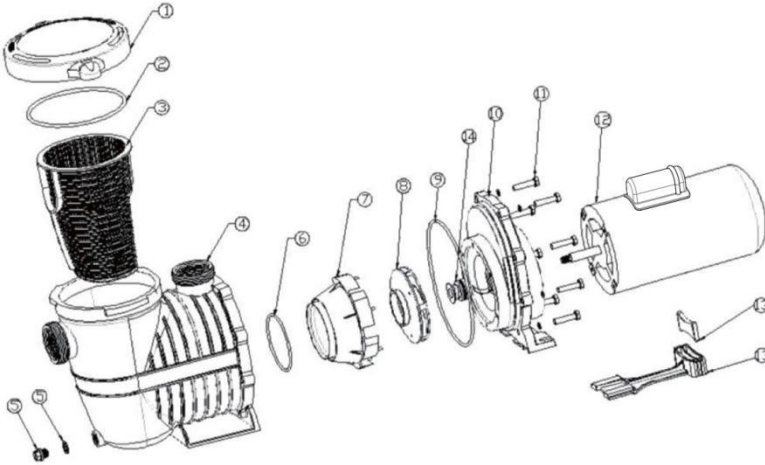

## PARTS

- |                 |                      |               |
|-----------------|----------------------|---------------|
| 1.Lid           | 6.Diffuser O-Ring    |               |
| 2.O-Ring        | 7.Diffuser           | 11.Screw      |
| 3.Strainer      | 8.Impeller           | 12.Motor      |
| 4.Strainer body | 9.Pump Casing O-Ring | 13.Carrier    |
| 5.Drain Plug    | 10. Pump Housing     | 14.Shaft Seal |

## INSTALLATION

### READ CAREFULLY AND SAVE THIS INSTRUCTION MANUAL



ATTENTION INSTALLER - THIS MANUAL CONTAINS IMPORTANT INFORMATION ABOUT THE INSTALLATION, OPERATION, AND SAFE USE OF THIS PUMP THAT MUST BE FURNISHED TO THE END-USER OF THIS PRODUCT. FAILURE TO READ AND FOLLOW ALL INSTRUCTIONS COULD RESULT IN SERIOUS INJURY.

## SAFETY PRECAUTIONS





Read this "Safety Precautions" before operation.

The below information should not be neglected for the proper use of this product. Your understanding can prevent harm or danger to the user or others.







**The following information is very important for safety in handling this product. Be sure to observe it.**

<b>DANGER</b>	Indicates an imminently hazardous situation that, if not avoided, will result in death or serious injury.	
<b>WARNING</b>	Indicates a potentially hazardous situation that, if not avoided, could result in death or serious injury.	
<b>CAUTION</b>	Indicates a potentially hazardous situation that, if not avoided, may result in minor or moderate injury, or property damage.	
<b>IMPORTANT</b>	 PROHIBITED	 ALERT

**DANGER**

	Stay off the main drain and away from all suction outlets.
	Strainer cover must be properly secured to prevent violent separation due to pressure in the circulation system.
	Before servicing, turn all the circulation system and pump controls off, make sure the filter manual air relief valve is in the open position, and all pressure is relieved.
	It is highly recommended that this product be installed and serviced by a qualified pool professional.

**WARNING**

	Remove pressure test plugs and/or plugs used in winterization of the pool/spa from the suction outlets. Fail to do so will result in an increased potential for suction entrapment.
	Do not permit children to play with this product.
	Before starting the system pump, all system valves must be set to allow system water to return to the pool.
	Do not operate the pool and spa circulation system if a system component is not assembled properly, damaged, or missing.
	Before working on any electrical equipment, turn off the power supply to the equipment.
	Connect only to a branch circuit protected by a ground-fault circuit interrupter (GFCI).

## CAUTION

❗	All electrical wiring must be in conformance with applicable local codes, regulations, and the National Electric Code (NEC).
❗	It is strongly advised to protect the electrical components from direct sunlight though this pump is designed for outdoor use.
❗	Place this pump in a well-drained area, one that will not flood when it rains.
❗	If installed within an outer enclosure or beneath the skirt of a hot tub or spa, adequate ventilation and free circulation of air must be provided to prevent overheating.
⊘	Do not install this pump in a damp or non-ventilated location. It requires free circulation of air for cooling.
⊘	Do not run the pump dry. Water acts as a coolant and lubricant for the mechanical shaft seal. Running the pump dry may damage seals, causing leakage, flooding, and voids warranty. Fill strainer housing with water before starting the motor.

## INSTALLATION

**Before servicing, all water circulation systems and pump controls must be off position and release all the pressure from the system.**

**WARNING:** This product should be installed and serviced by a qualified pool professional.

Locate the pump as close to the pool and water level as possible. Do not add too many elbow pipes in the plumbing so as to avoid suction reduction. It is highly recommended that the pump be placed in cool, dry places and avoid direct sunlight. Install the pump on a firm, level base or pad to meet all local and national codes. Fasten the pump to the base or pad with screws or bolts to further reduce vibration and stress on pipe or hose joints. The base must be solid, level, rigid, and vibration-free.

**WARNING:** Keep product away from children.

Use Teflon tape on the thread before screw fittings to pump inlet and outlet ports so as to avoid leakage. Do not over-tighten the fittings.

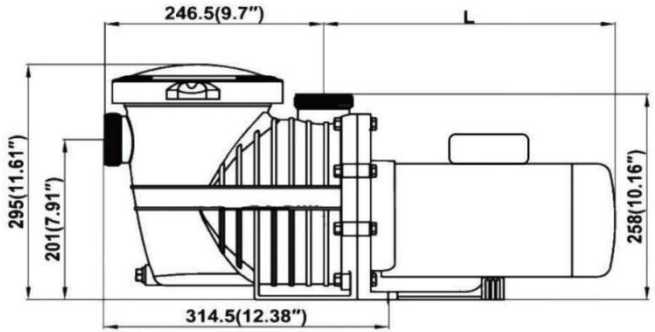

THP	1.5	2.0
L	13.58"(345mm)	14.17"(360mm)

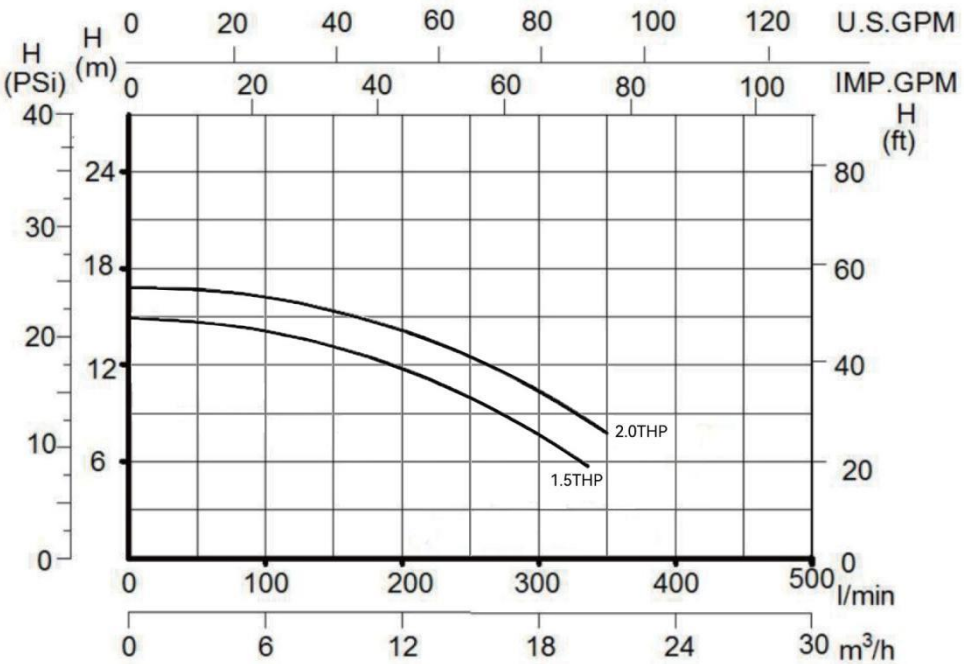

# WIRING

**WARNING:** All electrical wiring must conform to local codes, regulations, and the NEC.

**WARNING:** Turn off power to pump before working on electrical connections.

## For Single Speed Pumps

If the pump comes with a power cord, no wiring is needed.  
If not, wire the pump as below:

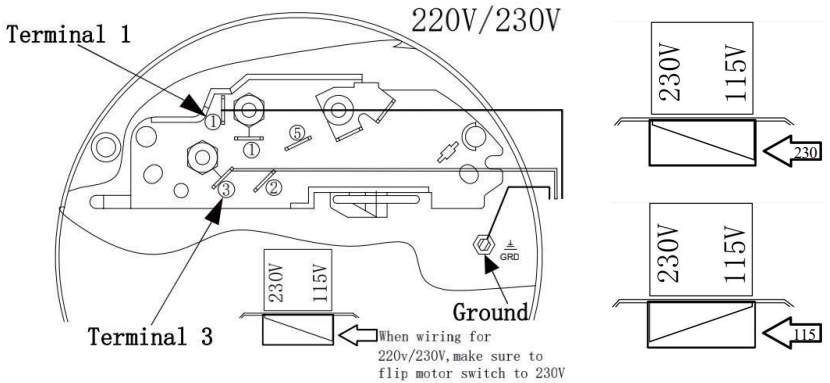

## How to wire 230V

- Make sure the switch is at the 230V side.
- Ground wire connects to the ground terminal.
- Hot wire connects to terminal 1 or 3; a neutral wire connects to terminal 3 or 1. Either hot wire or neutral wire is compatible with terminal 1 or 3.
- Turn on the power and run the pump.

## How to wire 115V

- Make sure the switch is at the 115V side.
- Ground wire connects to the ground terminal.
- Hot wire connects to terminal 1 or 3, a neutral wire connects to terminal 3 or 1. Either hot wire or neutral wire is compatible with terminal 1 or 3.
- Turn on the power and run the pump.

## For Two Speed Pumps

If the pump comes with a power cord, no wiring is needed.

If not, wire the pump as below:

- Ground wire connects to the ground terminal.
- If your power supply has two hot wires, connect them to each terminal marked with “Line”;
- If your power supply has one hot wire and one neutral wire, connect either of them to either of the terminal marked with “Line”.
- Turn on the power and run the pump.

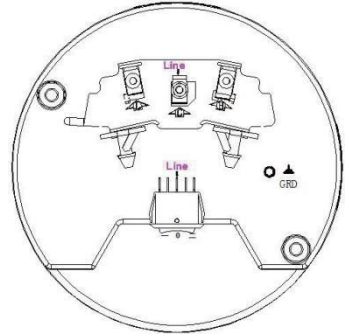

Make sure that the electrical supply available is suitable for the motor’s voltage, phase, and cycle, and that the wire size is adequate for the HP (kW) rating and distance from the power source.

**Warning:** All electrical wiring must be performed by a licensed electrician.

**Warning:** All electrical wiring must conform to local codes and NEC regulations.

**Warning:** Use copper conductors only.

### Electrical Guidance for 60Hz Single phase motors

Rated		Volts	Circuit Breaker Amps	Branch Fuse/ron Amps	Recommended Wire Size 0-50'
KW	HP				
0.37	0.5	115	15	15	No. 14
0.55	0.75	115	15	15	No. 14
		230	10	6.25	No. 14
0.75	1	115	20	20	No. 12
		230	10	9	No. 14
1.1	1.5	115	30	30	No. 10
		230	15	15	No. 14
1.55	2	115	30	30	No. 10
		230	15	12	No. 14
1.88	2.5	230	20	20	No. 12



Voltage from the power must be in the range from 90% to 110% of the motor nameplate rated voltage. Otherwise, the motor may overheat and result in overload tripping and reduced component life.

Install, ground, bond, and wire motor in accordance with local or NEC requirements.

The motor should be grounded permanently by connecting the ground terminal to the electrical service ground.

Bond motor to pool structure. Bonding will connect all metal parts within and around the pool with a continuous wire.

Bonding reduces the risk of current passing between bonded metal objects, which could potentially cause electrical shock if grounded or shorted.

## PRIMING

Fill strainer housing with water to suction pipe level. If water leakage occurs anywhere on the pump or filter, DO NOT start the pump. If no leakage occurs, stand at least 10 feet from the pump and/or filter and proceed with starting the pump.

Turn on the power and wait for the pump to prime, which may take up to five (5) minutes. Priming time will depend on the vertical length of the suction lift and the horizontal length of the suction pipe. If the pump does not prime within five minutes, stop the motor and determine the cause. Make sure all suction and discharge valves are open when the pump is running. See Troubleshooting Guide.

## SERVICING

**Warning:** Stop the pump and release all pressure from the circulation system before servicing.

Check the status of the pump regularly. Clean the strainer immediately if it is full of debris. Make sure the environment is ventilated enough for the motor to cool itself.

If any problem is found on the pump, see the Troubleshooting Guide to determine the cause and contact the distributor to get spare parts for replacement. See Parts Guide.

## STORAGE

In order to keep the pump from the freeze in winter, please drain the pump properly:

- Keep the water level below the inlet of the pool.
- Pull out the drain plug from the pump strainer body and remove the strainer lid.
- Disconnect pump from mounting pad, wiring system, and piping system.
- Once water is drained off from the pump, reassemble the strainer lid and drain plugs.
- Place pump in a shady and dry area.

**Warning:** Turn off the power and release all pressure before draining the pump.

## TROUBLE SHOOTING

### MOTOR WILL NOT START

- Improper or loose wiring connections; open switches or relays; tripped circuit breakers, GFCI's, or blown fuses.
- Manually check rotation of motor shaft for free movement and lack of obstruction.
- If you have a timer, make sure it is working properly. Bypass it if necessary.

## TROUBLE SHOOTING(CONTINUED)

### MOTOR SHUTS OFF

- Undersized wiring; loose connections; etc.
- Low voltage at motor or power drop (frequently caused by undersized wiring or extension cord use).
- Mechanical binding and electrical overload.

### MOTOR HUMS BUT DOES NOT START

- Centrifugal switch stuck in the OPEN position.
- Binding of the motor shaft.

### PUMP WON'T PRIME

- Make sure pump strainer housing is filled with water and the cover O-ring is clean; also, be sure it is properly seated in the cover O-ring groove. Make sure the strainer cover is locked firmly in position and lubricated with "Jack's 327".
- Make sure all suction and discharge valves are fully open and not blocked, that the pool water level is at a proper level and that the skimmer weir is not hung up or stuck on the skimmer wall.
- Block off to determine if the pump will develop a vacuum. You should have 5"-6" of vacuum at the strainer cover. You may be able to check by removing the skimmer basket and holding your hand over the bottom port with the skimmer full and pump running. If no suction is felt, check for line blockage.
- a. If pump develops a vacuum, check for a blocked suction line or dirty strainer basket, and an air leak in the suction piping may be the cause.
- b. If the pump does not develop a vacuum and the pump has sufficient "priming water":
  - i. Re-check strainer housing cover and all threaded connections for suction leaks. Check if all hose clamps are tight.
  - ii. Check voltage to ensure that the motor is rotating at full RPM.
  - iii. Open housing cover and check clogging or obstruction in suction. Check impeller for debris.
  - iv. Remove and replace shaft seal only if it is leaking.



---

## LOW FLOW

- Clogged or restricted strainer or suction line; undersized pool piping.
  - Plugged or restricted discharge line or filter, valve partially closed (high gauge reading).
- How to correct: Backwash strainer as per manufacturer's instructions;
- Air leak in suction piping causing rumbling in the pump.
  - Cavitation due to restricted or undersized suction line or leak at any joint, low water level in the pool, and unrestricted discharge return lines. Correct suction condition or throttle return lines, if practical.

## NOISY PUMP

- Vibration due to improper mounting, etc. Put a rubber pad under metal mounting feet.
- Foreign matter in the pump housing. Loose stones/debris hitting the impeller could be the cause; remove any above.
- Motor bearings noisy from normal wear, rust, overheating, or concentration of chemicals causing seal damage which will allow chlorinated water to seep into bearings wiping out the grease causing bearing to whine. All seal leaks should be replaced at once.
- Equipment base vibrating.

**VEVOR<sup>®</sup>**

E-mail: [CustomerService@vevor.com](mailto:CustomerService@vevor.com)